

WOLF®

CLOTH DRILLS • PARTS CATALOG

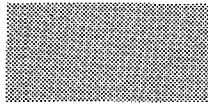

MODEL X — STRAIGHT DRILL
MODEL KX — KNEE ACTION
MODEL KXH — KNEE ACTION
HOT DRILL

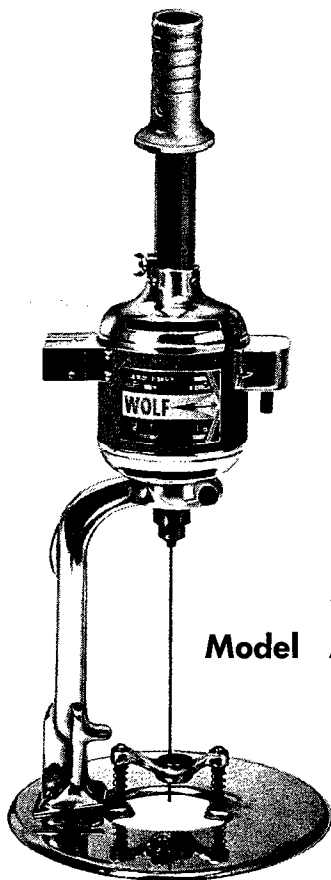

Model X

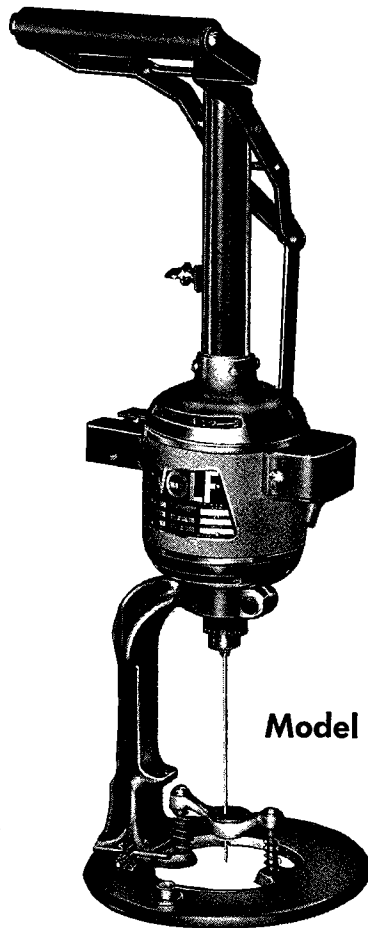

Model KX

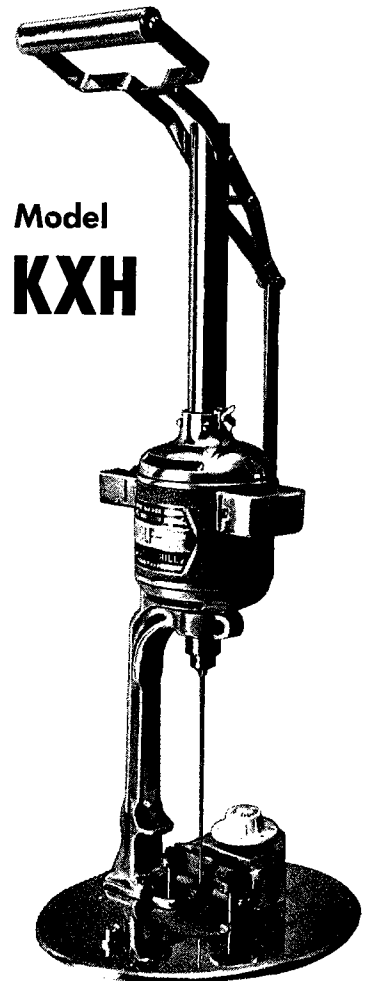

Model
KXH

WARNING

Always exercise care when handling or using this machine. Disconnect electrical connector before performing adjustments, maintenance or repairs. Never touch heater unit or surrounding parts when heater unit is in operation or soon after operation. Never operate drill without a drill-needle in the chuck or spindle could become damaged.



WOLF® *1st/Since 1888*

THE WOLF MACHINE COMPANY

5570 Creek Road ■ Cincinnati, OH 45242 ■ USA
Phone: 513-791-5194 ■ Telex #275189 WEPCO
FAX 1-513-791-0925 ■ TOLL FREE 1-800-543-WOLF

From the library of: Superior Sewing Machine & Supply LLC

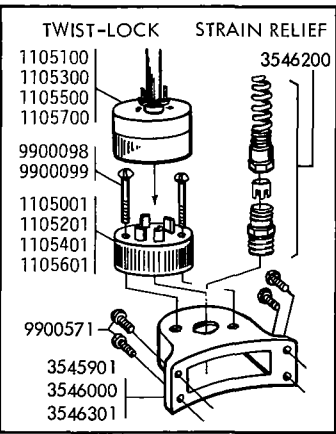

ILLUSTRATION FOR MODELS KX, KXH, and X

MODEL KXH KNEE ACTION HOT DRILL

Uses the KX part numbers and KXH Heater Unit part numbers. Note: On hot drills the clear plastic base is not available. Only Type 'A' drill sizes are available for hot drills (see page 5).

MODEL X STRAIGHT DRILL

Uses the same parts as KX Drill except for knee action handle. Numbers indicated by a ★ (symbol) are not used on X Straight Drill.

MODEL KX KNEE ACTION DRILL

Use all parts except: Heater Unit parts 1808100 Bracket, 1089400 Handle and 9900822 Screw.

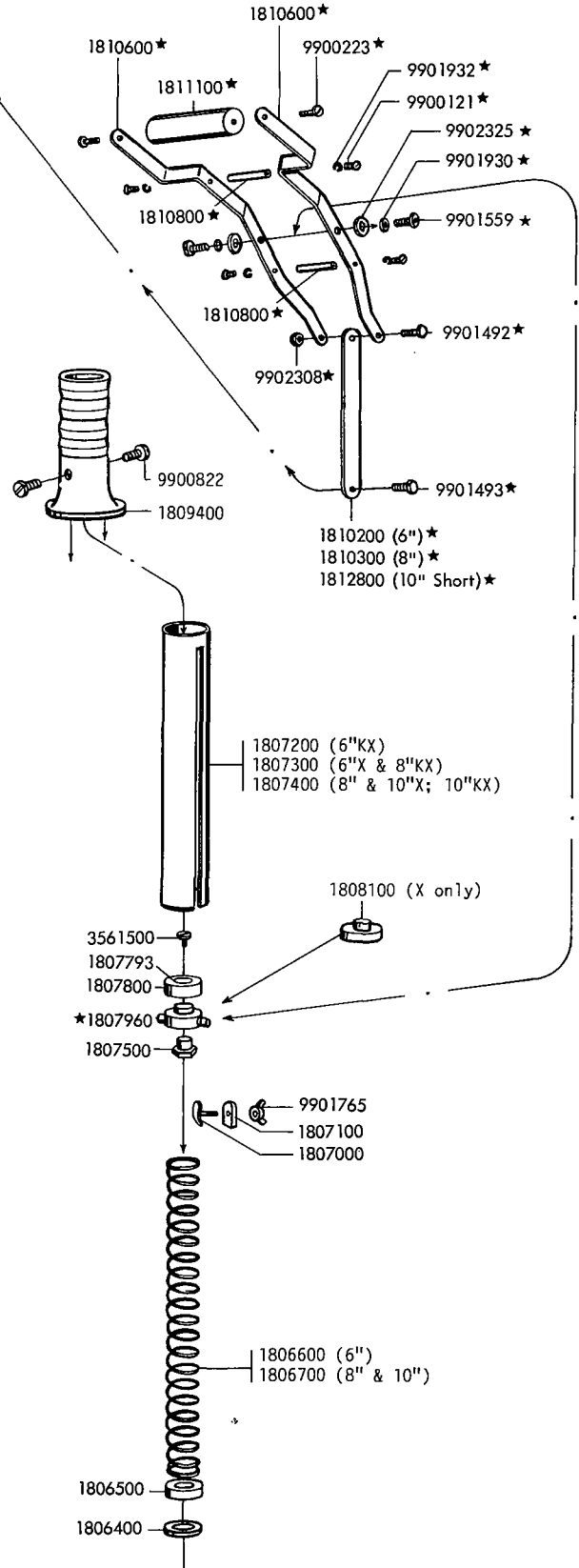
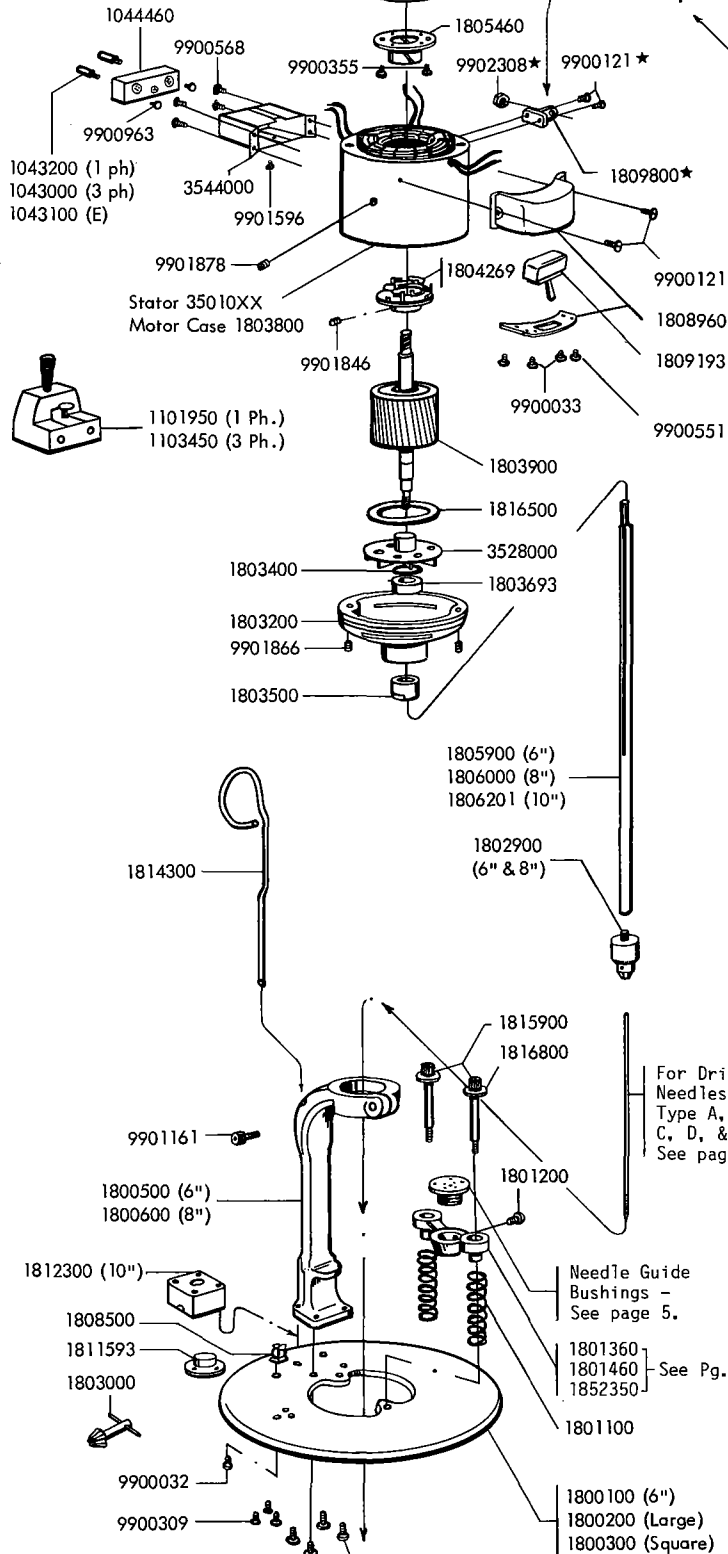

For Drill Needles: Type A, B, C, D, & P. See page 5.

Needle Guide Bushings - See page 5. 1801360, 1801460, 1852350. See Pg. 5

PARTS LIST FOR MODELS KX, KXH, and X

Part No.	Description	Quantity used if more than 1	Part No.	Description	Quantity used if more than 1
1043000	Connection Post 3/16" 3 Phase		1808960	Switch Box S.A.	
1043100	Connection Post 1/8" 1 Phase		1809193	Switch	
1043200	Connection Post 1/4" 1 Phase		1809400	Handle for Model X	
1044460	Connector Block		★1809800	Bracket	
1101950	1 Phase Cord Coupling - Wolf		★1810200	Link Rod 6"	
1103450	3 Phase Cord Coupling - Wolf		★1810300	Link Rod 8"	
1105001	110/1 Phase Twist-Lock Male Plug		★1810600	Handle Bar	2
1105100	110/1 Phase Twist-Lock Female Plug		★1810800	Spacer	2
1105201	220/1 Phase Twist-Lock Male Plug		★1811100	Handle (Aluminum)	
1105300	220/1 Phase Twist-Lock Female Plug		1811593	Level	
1105401	220/3 Phase Twist-Lock Male Plug		1812300	Riser Block for Standard - 10" only.	
1105500	220/3 Phase Twist-Lock Female Plug		★1812800	Link Rod 10" Short	Both Req'd
1105601	440/3 Phase Twist-Lock Male Plug		★1812900	Link Rod 10" Long (Not illust.)	on 10"
1105700	440/3 Phase Twist-Lock Female Plug		1815900	Needle Guide Post	
1119993	1 Phase Cord Coupling - Eastman (Not illust.)		1816500	Baffle Ring	
1800100	6" Base Plate (round)		1816800	Retaining Ring (for Guide Post)	
1800200	Base Plate - Large Oval (Not illust.)		1852350	Floating Needle Guide Assy. (for 5/16" thru 11/16" needles) See Pg. 5.	
1800300	Square Plexiglass Base Plate (Not illust.)		3501001	Stator 110-1-60	
1800500	6" Standard		3501002	Stator 110-1-50	
1800600	8" Standard		3501004	Stator 220-1-50	
1801100	Needle Guide Spring	2	3501005	Stator 220-1-60	
1801200	Adjusting Screw (Needle Guide Bushing)		3501011	Stator 220/380-3-50/60	
1801360	Floating Needle Guide Assy. (for 1 Hole Bushings - See page 5.)		3501013	Stator 220-3-50/60	
1801460	Floating Needle Guide Assy. (for 3 & 5 Hole Bushings - See page 5.)		3528000	Fan	
1801500	Replaceable Bronze Bushing (for 1801460 only - Not illust.)		3544000	Connector Box - Wolf	
1802600	Single Hole Bushing 1/16" Long Type		3545901	Inlet Box Twist-Lock 1 Phase Plug	
1802700	Single Hole Bushing 5/64" Long Type		3546000	Inlet Box - European	
1802800	Single Hole Bushing 3/64" Long Type		3546200	Strain Relief	
1802900	Needle Chuck		3546301	Inlet Box Twist-Lock 3 Phase Plug	
1803000	Chuck Wrench		3561500	Shaft End Screw (Left Hand)	
1803200	Bottom Head - Motor		9900032	Screw to secure 1808500	
1803300	Top Head - Motor		9900033	Screw to secure 1809193	2
1803400	Bearing Retainer		9900098	Screw for 1 Phase Plug	3
1803500	Bearing Locknut		9900099	Screw for 3 Phase Plug	2
1803693	Bearing - Top and Bottom	2	★9900121	Screw to secure 1810800	4
1803800	Motor Case		★9900121	Screw to secure 1809800	2
1803900	Rotor		9900121	Screw to secure 1808960	2
1804100	Motor Bolts	2	★9900223	Screw to secure 1811100	2
1804269	Outer Circuit Breaker S.A.		9900309	Screw to secure 1811593	3
1805460	Inner Circuit Breaker		9900355	Screw to secure 1805460	2
1805600	Insulator		9900420	Screw to secure 1800500 or 1800600	4
1805900	6" Spindle		9900431	Screw to secure 1812300 w/1800600	4
1806000	8" Spindle (Not illust.)		9900551	Screw to secure 1808900	2
1806100	Driving Clutch		9900568	Screw to secure 3544000	4
1806201	Spindle - 10"		9900569	Screw to secure 1807200	4
1806400	Spring Retaining Washer		9900571	Screw to secure Inlet Box	4
1806500	Tube Expansion Washer		9900822	Screw to secure 1809400	2
1806600	Spring - for 6"		9900963	Screw to secure Wire to 1044460	2 or 3
1806700	Spring - for 8" & 10"		9901161	Standard Locking Screw	
1807000	Locking Bolt		★9901492	Screw to secure Link Rod to Handlebar	
1807100	Depth Gauge Block		★9901493	Screw to secure Link Rod to 1809800	
1807200	Tube 6" KX		★9901559	Screw to secure Handle Assy. to 1807960	2
1807300	Tube 6" X & 8" KX		9901596	Screw to secure 1044460	3
1807400	Tube 8" & 10" X; 10" KX		9901765	Depth Gauge Wing Nut	
1807500	Shaft End Bushing		9901846	Set Screw for 1804269	
1807793	Shaft End Thrust Bearing (contained in 1807800)		9901866	Set Screw	2
1807800	Thrust Bearing Container		9901877	Screw for 1808400 (Not illust.)	4
★1807960	Thrust Bearing Retainer & Handle Bracket		9901878	Screw to secure Stator	2
1808060	Handle Bracket (Old Model X drill - Not illust.)		9901930	Lockwasher for 9900569	4
1808100	Handle Bracket		★9901930	Lockwasher for 9900087	2
1808400	Operating Handle (Old Model X drill - Not illust.)		★9901932	Lockwasher for 9900121	4
1808500	Spring Clip Holder for Chuck Wrench		★9902308	Nut for 9901493	2
			★9902325	Washer for 9900087	2

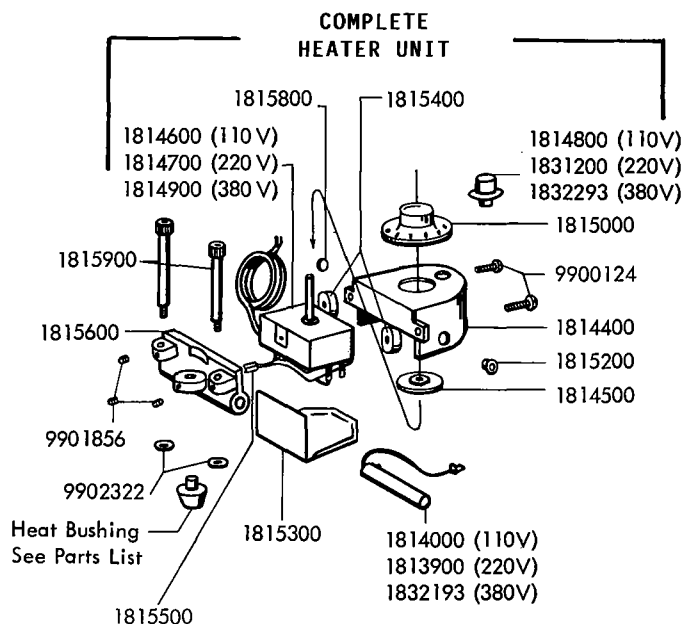

HEATER UNIT PARTS for XH and KXH DRILLS

Part No.	Description	Quantity used if more than 1
Heater Bushing		
1813100	3/64 Heater Bushing	1813500 1/8 Heater Bushing
1813200	1/16 Heater Bushing	1813600 5/32 Heater Bushing
1813300	5/64 Heater Bushing	1813700 3/16 Heater Bushing
1813400	3/32 Heater Bushing	1813800 1/4 Heater Bushing
1813900	Heater 220 Volt	
1814000	Heater 110 Volt	
1814159	Heater Unit Complete 220 Volt	
1814259	Heater Unit Complete 110 Volt	
1814269	Heater Unit Complete 380 Volt	
1814300	Wire Cover	
1814400	Control Housing	
1814500	Nut to secure Control	
1814600	Control 110 Volt	
1814700	Control 220 Volt	
1814800	Pilot Light 110 Volt	
1814900	Control 380 Volt	
1815000	Dial	
1815200	Wire Grommet	
1815300	Insulator Cover	
1815400	Insulator Spacer	2
1815500	Wire Terminal Clip (not illust.)	5
1815600	Heater Housing	
1815800	Plug	
1815900	Guide Post	2
1831200	Pilot Light 220 Volt	
1832193	Heater 380 Volt	
1832293	Pilot Light 380 Volt	
9900124	Screw to secure 1814400	2
9901856	Set Screw	3
9902322	Washer	2

INSTRUCTIONS FOR OPERATING HEATER UNIT

WARNING Never touch Heater Unit or surrounding parts when unit is in operation. Touching it could cause severe burn.

1. Set Dial (1815000) to desired temperature (number). The red light will indicate when power is on. The higher the number, the higher the temperature. Most materials use a 6-7 setting, however other settings may be determined that will better suit a particular fabric.
2. Silicone may be sprayed on the needle when using the Heater Unit to prevent freezing of the drill in the bushing (such as 'Dow Corning Fabriglide').

**WARNING: ALWAYS
EXERCISE CARE
WHEN HANDLING OR
USING MACHINERY.**

WOLF CLOTH DRILLS

	TYPE A ROUND POINT		ADAPTOR ON TYPE A	TYPE B, BAYONET POINT		ADAPTOR ON TYPE B	TYPE C GROOVED POINT		ADAPTOR ON TYPE C	TYPE D HOLLOW POINT		ADAPTOR ON TYPE D	TYPE P		ADAPTOR ON TYPE P	
SIZES AVAIL.	6"	8"	10"	6"	8"	10"	6"	8"	10"	6"	8"	10"	6"	8"	10"	
3/64	1832000	1832100	1820060	1835300	1835400	1820160								1845500	1845600	1820460
1/16	1832300	1832400	1821060	1835600	1835700	1821160								1845800	1845900	1821460
5/64	1832600	1832700	1822060	1837400	1837500	1822160	1837700	1837800	1822260					1846100	1846200	1822460
3/32	1832900	1833000	1823060	1835900	1836000	1823160	1838300	1838400	1823260	1841900	1842000	1823360		1846400	1846500	1823460
1/8	1833200	1833300	1824060	1836200	1836300	1824160	1838600	1838700	1824260	1842200	1842300	1824360		1846700	1846800	1824460
5/32	1833500	1833600	1825060	1836500	1836600	1825160	1838900	1839000	1825260	1842500	1842600	1825360		1847000	1847100	1825460
3/16	1833800	1833900	1826060	1836800	1836900	1826160	1839200	1839300	1826260	1842800	1842900	1826360		1847300	1847400	1826460
1/4	1834100	1834200	1827060	1837100	1837200	1827160	1839500	1839600	1827260	1843100	1843200	1827360		1847600	1847700	1827460
5/16							1839800	1839900		1843400	1843500					
3/8										1843700	1843800					
7/16										1844000	1844100					
1/2										1844300	1844400					
9/16										1844600	1844700					
5/8										1844900	1845000					
11/16										1845200	1845300					

WHEN ORDERING STATE MODEL NUMBER AND SIZE OF MACHINE.

NEEDLE GUIDES AND BUSHINGS

1801360 Floating Needle Guide Assy. (for single hole Bushing)	1801900	Bushing 1/16" Short Type
	1802000	Bushing 3/32" Short Type
	1802100	Bushing 1/8" Short Type
	1802200	Bushing 5/32" Short Type
	1802300	Bushing 3/16" Short Type
	1802400	Bushing 1/4" Short Type
	1802410	Bushing 5/16" Short Type
1801460 Floating Needle Guide Assy. (for 3 & 5 hole Bushings)	1801700	5 hole Bushing for 3/64" 1/16", 5/64", 3/32" and 1/8" Needles
	1801800	3 hole Bushing for 5/32" 3/16", 1/4" Needles.
1852350 Floating Needle Guide Assy. (for single hole large size drills, 5/16" thru 11/16")	1852600	Bushing 7/16"
	1852700	Bushing 1/2"
	1852800	Bushing 9/16"
	1852900	Bushing 5/8"
	1853000	Bushing 3/8"
	1853100	Bushing 11/16"
1853200	Bushing 5/16"	

ACTUAL HOLE SIZES FOR TYPE D HOLLOW POINT DRILL BITS

6"	8"	HOLE SIZE
1841900	1842000	1/16" = .062
1842200	1842300	3/32" = .094
1842500	1842600	1/8" = .125
1842800	1842900	9/64" = .141
1843100	1843200	3/16" = .187
1843400	1843500	1/4" = .250
1843700	1843800	5/16" = .312
1844000	1844100	3/8" = .375
1844300	1844400	7/16" = .437
1844600	1844700	1/2" = .500
1844900	1845000	9/16" = .562
1845200	1845300	5/8" = .625